

The Crown: Sleep Dearie Sleep

Season 6 Episode 10

Martin Childs : December 2023



THE
C R O W N

Season 6 Episode 10

‘ S L E E P D E A R I E S L E E P ’

After 60 episodes and 2448 sets, over six decades of story, the art department’s work on *The Crown* is finished.

Sleep Dearie Sleep (or Episode 60 as we like to remind people) brings the story into the twenty-first century.

The brief we gave ourselves came straight from Peter Morgan’s script and from conversations with Stephen Daldry. As a result we shed any 20:20 hindsight that might sentimentalise the story and told what was on the page.

The biggest challenge: to recreate St George’s Chapel, Windsor, begun in 1475 and completed in 1528. Of all the locations within our grasp, the closest in character was York Minster. However, York Minster lacked two important things: the first was any resemblance to the altar end of St George’s; the second was sufficient time to transform it – just one day, with two more to shoot (between Easter services and a visit from The King.) Our construction team built and painted, in forensic detail, a sixty-foot wide, eighteen-foot high replica of St George’s Chapel in the Elstree workshop, pulled it apart, drove it 200 miles up the A1, and reassembled it in a day, to look seamless in a building that had taken 250 years to complete.

That was just one of our many adventures.

Sleep Dearie Sleep contains 75 new sets among a small handful of more familiar anchors that have shown, over 60 hours, a contrast to the passage of time.

As well as an end to nine years of designing, *Sleep Dearie Sleep* is a kind of elegy, but one that looks to the future.



THE
CROWN

Season 6 Episode 10

'SLEEP DEARIE SLEEP'

Westminster Abbey

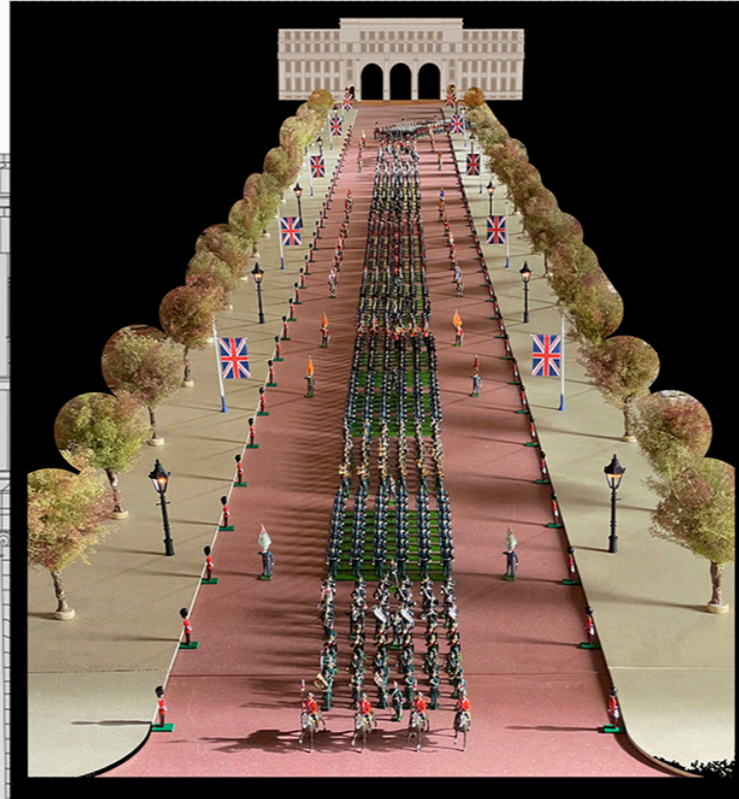

The Mall

THE CROWN

Admiralty Arch

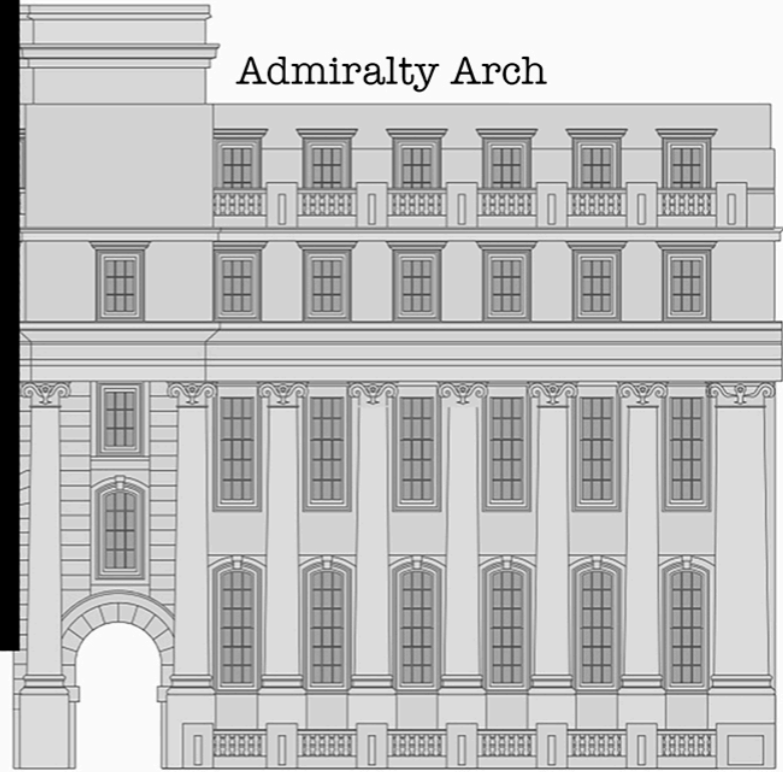

Buckingham Palace

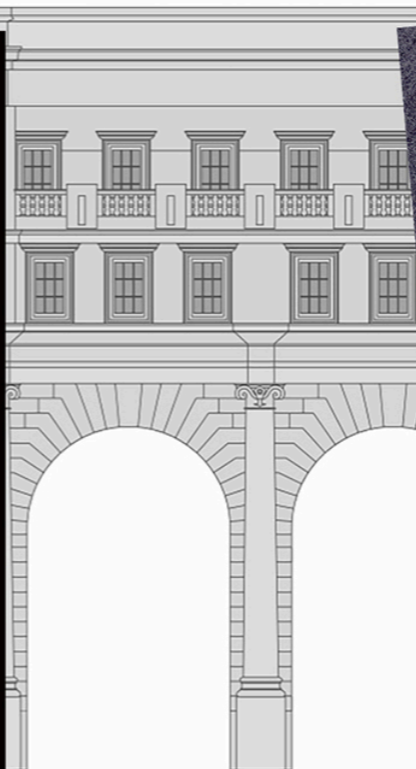
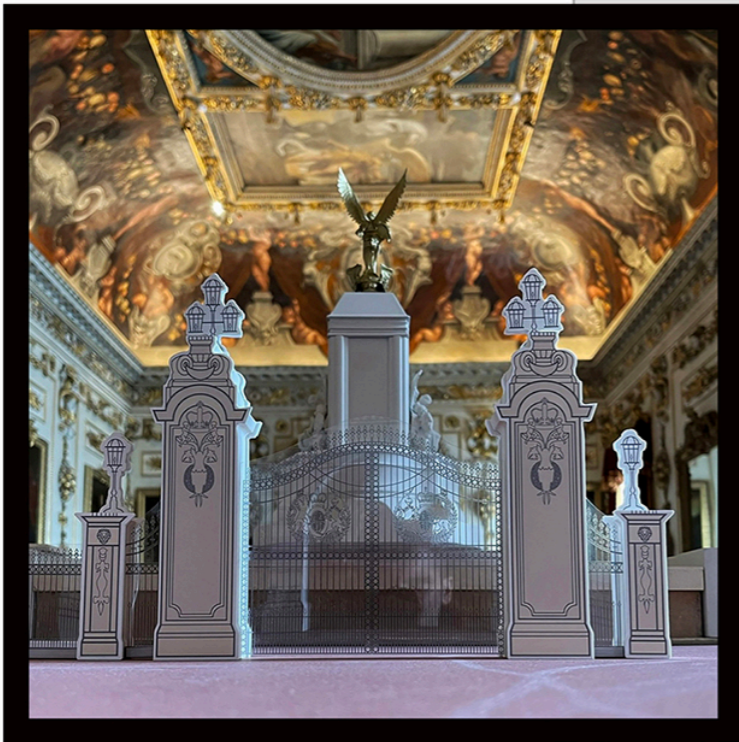

PLANNING DOCUMENTS





THE QUEEN IS SHOWN A MODEL OF THE MALL FOR A FUTURE CEREMONIAL EVENT





THE
CROWN

Season 6 Episode 10

'SLEEP DEARIE SLEEP'

98969

110 rear body tub to be extended to work with the wheelbase of the defender 130 chassis to become an open top rear section where coffin will sit.

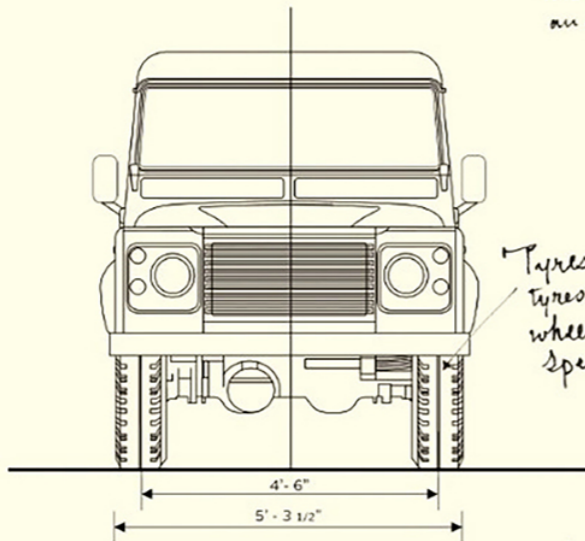

Tyres: fit with G90 tyres and 'wolf' wheels are military spec.

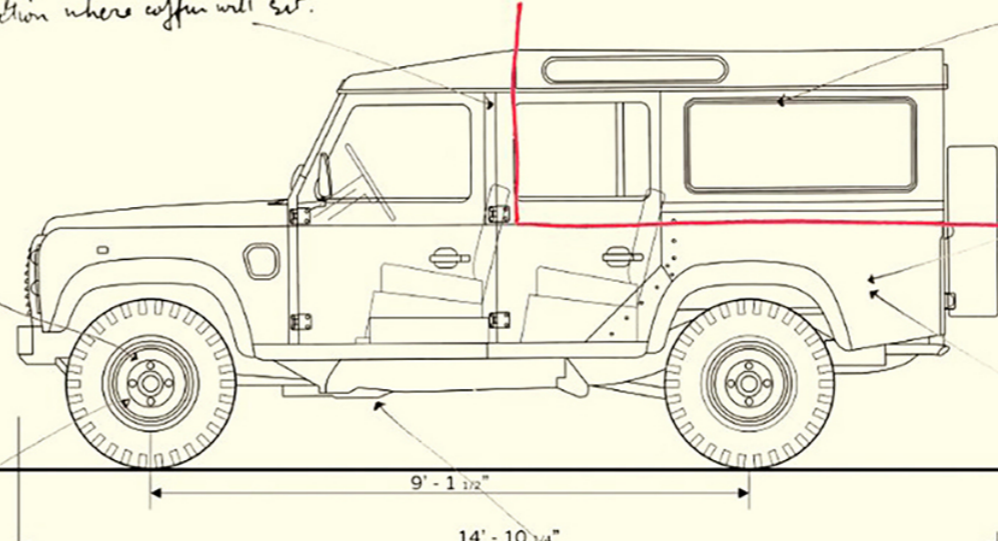

Open Section where coffin can be placed on metal spindles with rubber ends to support coffin in transit!

Hatch Doors: Open down & not to the side.

A centre brace: can fold out to the ground so that the bearings can slide out the coffin with more ease!

Cut into either side of the new back section will be 2 curved windows - allowing for extra visibility

Wheel base will increase from 9'-1" to 10'-7"

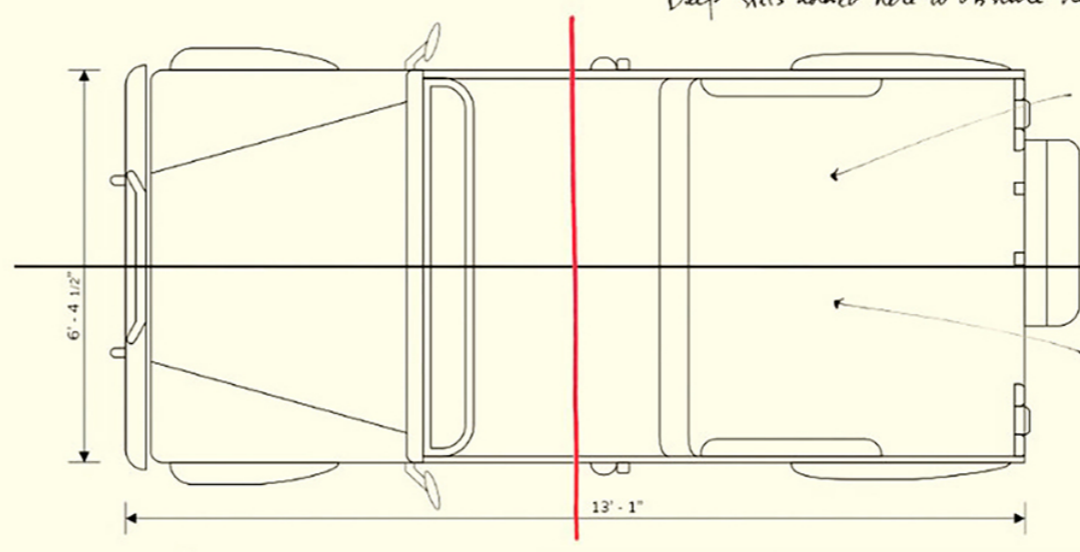
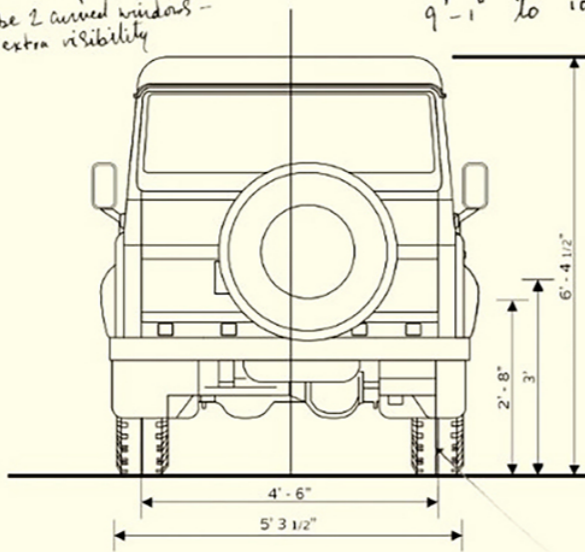

Deep sills added here to obscure the view of the chassis

Open Section where coffin can be placed on metal spindles with rubber ends to support coffin in transit!

For non-parade hauls, the long, external strap hinges on the heavy steel rear hatch allow the coffin to be slipped discreetly for carriage inside the 'bed'.

Paint: re-spray in Deep bronze green



Tyres: fit with G90 tyres and 'wolf' wheels are military spec

Drawing No. 5620_192
Date: 5620_192
Signature: [Signature]

DWN	B.D Young	05/01/2005	ISSUED BY			
CHK	F.BURROWS	05/01/2005	LAND ROVER SOLIHULL, DUKE OF EDINBURGH			
APVD	I.CROSSLAND		NAME			
PRODUCT SPEC	LAND ROVER DEFENDER TD5 130 CHASSIS CAB MODIFIED HEARSE					
APPLICATION SPEC	SIZE	CODE	DRAWING No.	RESTRICTED TO		
FINISH	A3	493-43	49300-39394	AJS-281		
DIMENSIONS	IMPERIAL	SCALE	1/2"-1"	SHEET	1 OF 1	



garden, Buckingham Palace

The Crown Season 6



Windsor Castle, The Queen's Drawing Room

MC January 2022

THE WEDDING

during

before

after

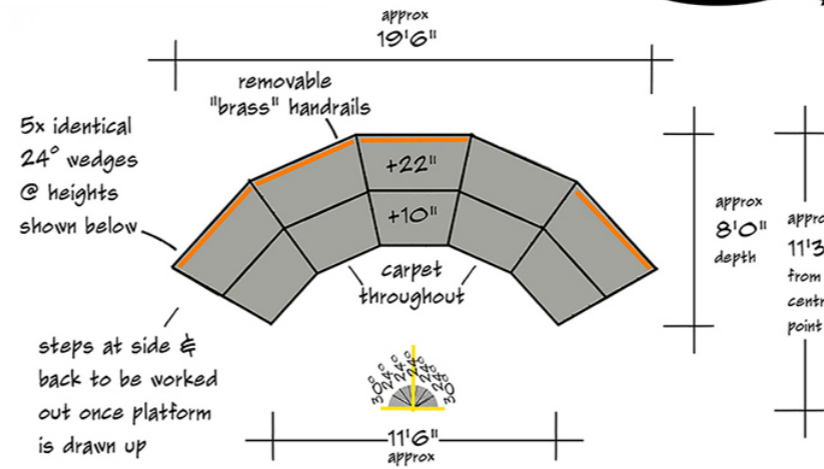
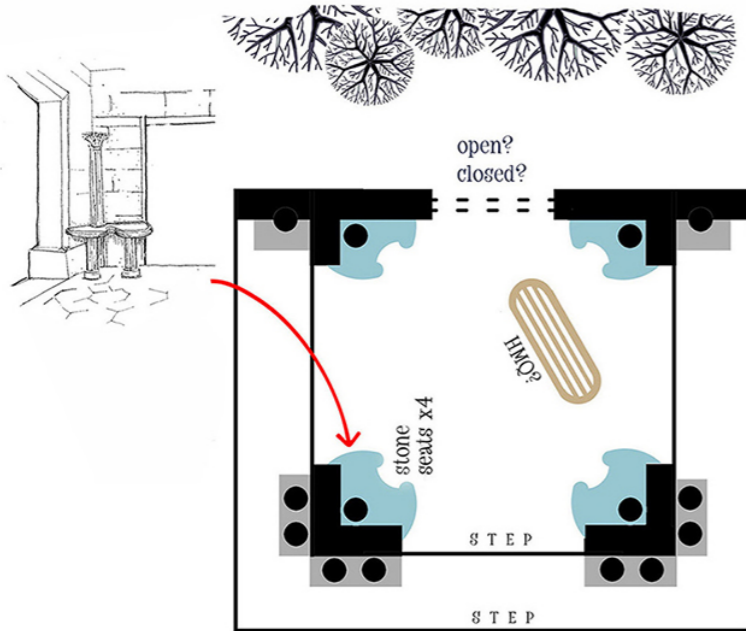

L-R: Philip Elizabeth Charles Camilla Shand-dad

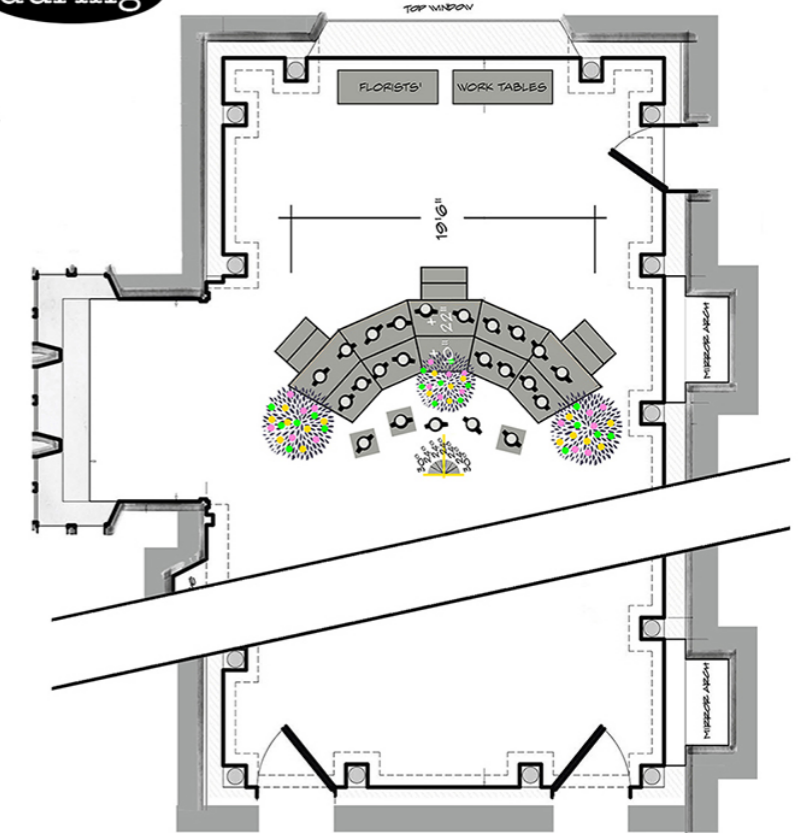

Stage for Wedding Photo, Windsor Castle

THE CROWN

through many years
will find that there
have no doubt: you will
not win with many

Today has been a
single happy event
together. The Grand
twenty minutes ago
follows:

In other
wedding in
Darren Des
excessive ex

Almost
chapel at
of another
Prince.
to man
other side
had to
Senior,
married
marriage

Being Pr
happiness.
be condense
job one c
years and
that you h
Several pres
but with a
endearment.

It has become
is for life. I
upon those w
monarchs, to
been depose
most often.
then, with

5.

However, there is another cherished axiom that can be
weighed against this. That the Crown is adaptable. How
Accommodating. That it responds to new conditions. How
else has it lasted a thousand years? With this in mind,
I have begun to reflect on my position. While the word
'abdication' is fraught with connotations, there is another
I would propose in its place. Retirement. Having become
their presumptuous in the glare of public scrutiny with
entire adult life in the little opportunity to follow my own pursuits.

THE QUEEN'S SPEECH



7.
With Charles's marriage, he has removed the
final hindrance to his accession. It is with
pleasure, and not a little relief, that I make
this announcement to you. This old horse has
run its race. It's time to make way for a
younger stallion in his prime. Charles, I have
observed you through many years of training.
In any race you will find that there are hurdles.
But of this I have no doubt:

THE
CROWN

Season 6 Episode 10

'SLEEP DEARIE SLEEP'

THE
C R O W N

How to transform York Minster into
St George's Chapel, Windsor,
in a day and a half

new altar screen 50' x 16'
across entire width of existing building
SEE DRAWING

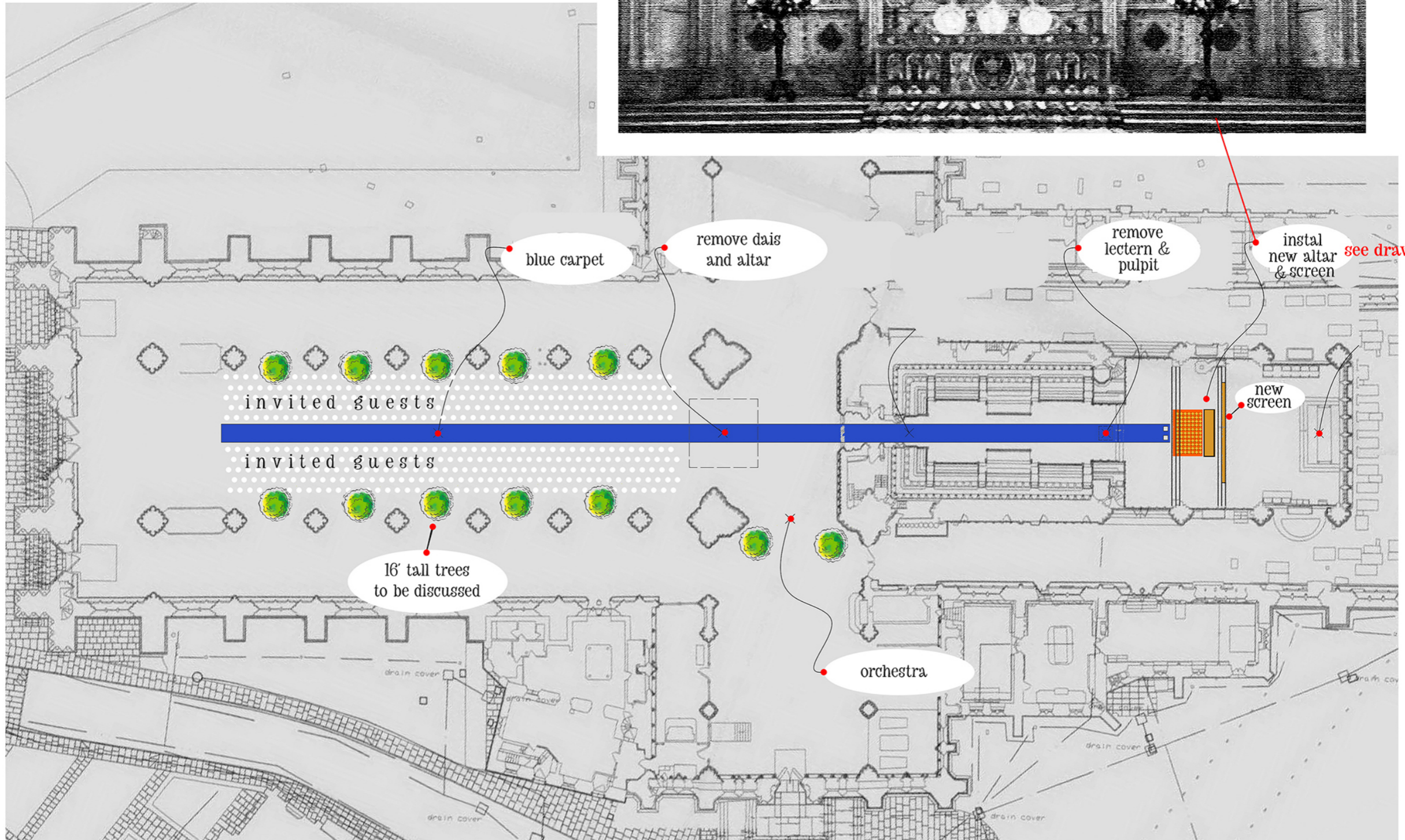
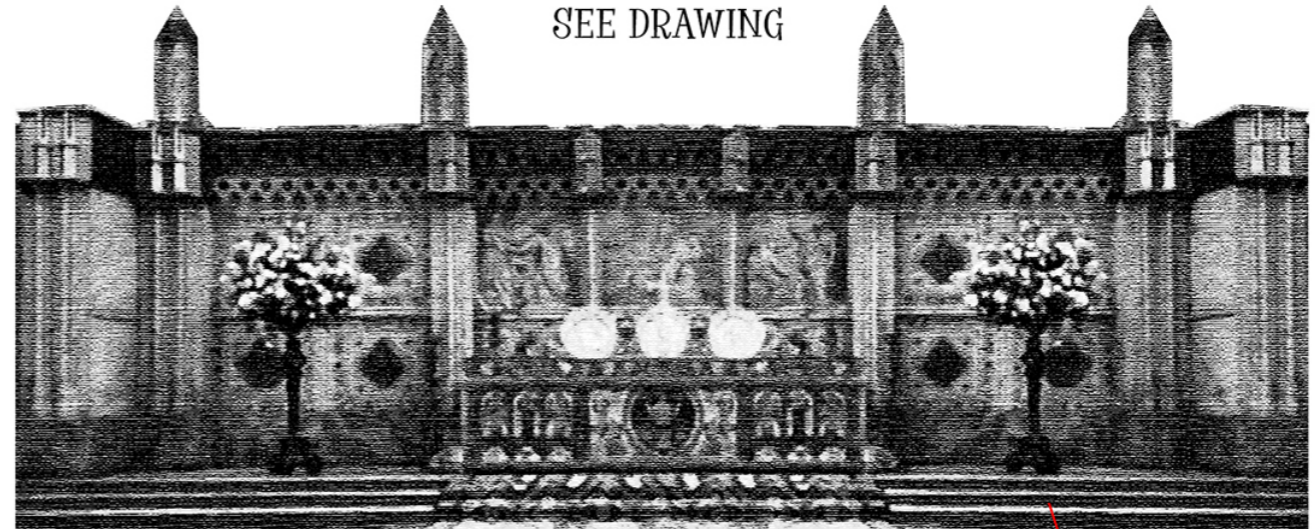



St George's Chapel, Windsor

THE
CROWN

MC



THE
CROWN

Season 6 Episode 10

'SLEEP DEARIE SLEEP'



THE
CROWN

Season 6 Episode 10

'SLEEP DEARIE SLEEP'



MC December 2023

THE
CROWN

'SLEEP DEARIE SLEEP'