

Created by
JULIO TORRES

Production Designer
TOMMASO ORTINO

HBO ORIGINAL

FANTASMAS





ISOLATION & SKELETON

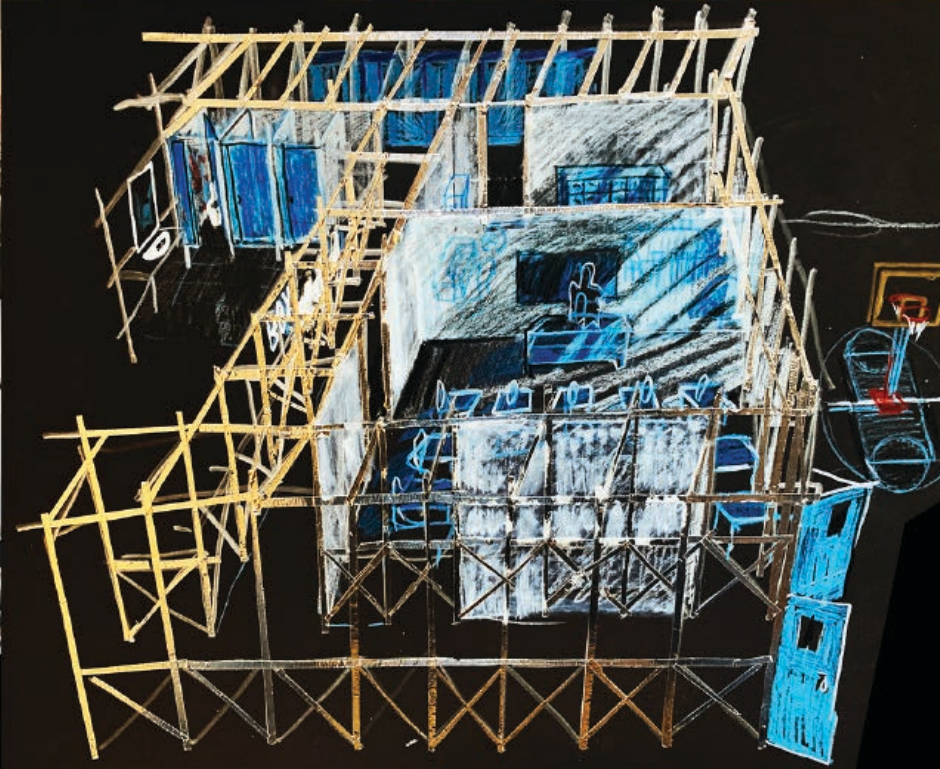

**WE WOULD ISOLATE
OUR SETS
SURROUNDING
THEM WITH
DARKNESS**



**WE WOULD STRUCTURE
THEM WITH A SKELETON
CREATED WITH METAL
PIPES THAT WOULD
MIMIC
SCAFFOLDING**

BACKDROP



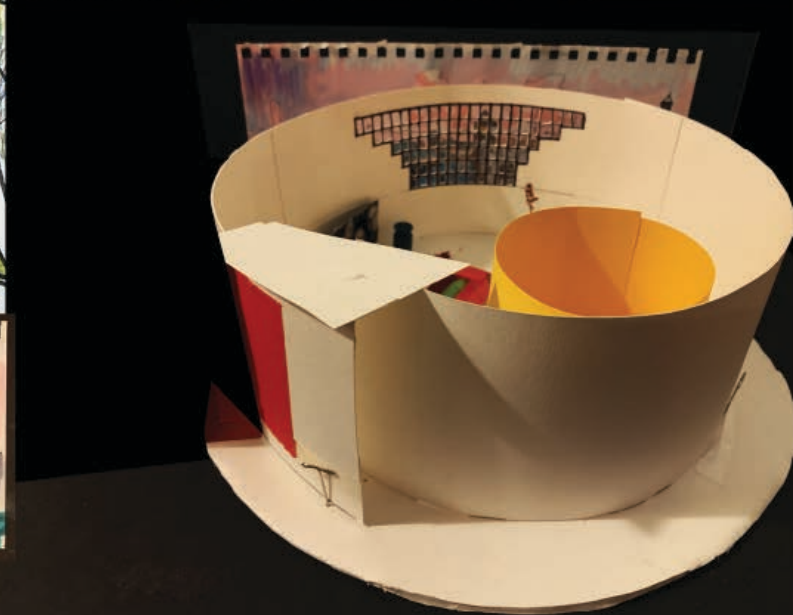

PAINTED BACKDROPS WOULD FILL OUR OPENINGS
WINDOWS AND DOORS WOULD OPEN TO OUR PAINTED SURREAL AND EERIE VERSION OF NEW YORK



**WE HAD 4 PHASES OF CONSTRUCTION
TO ALLOW US TO BUILD EVERYTHING
IN OUR SCHEDULE AND ONE BIG SINGLE STAGE**

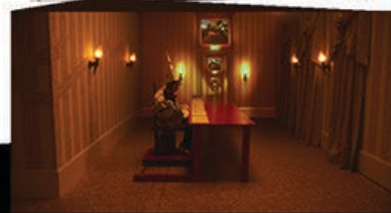
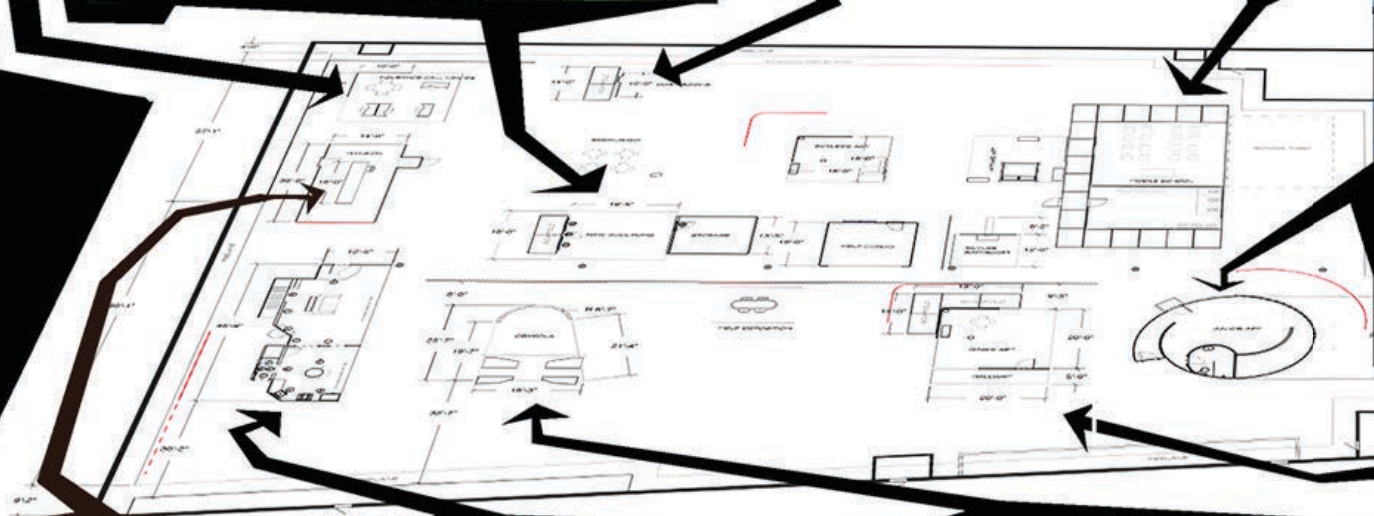

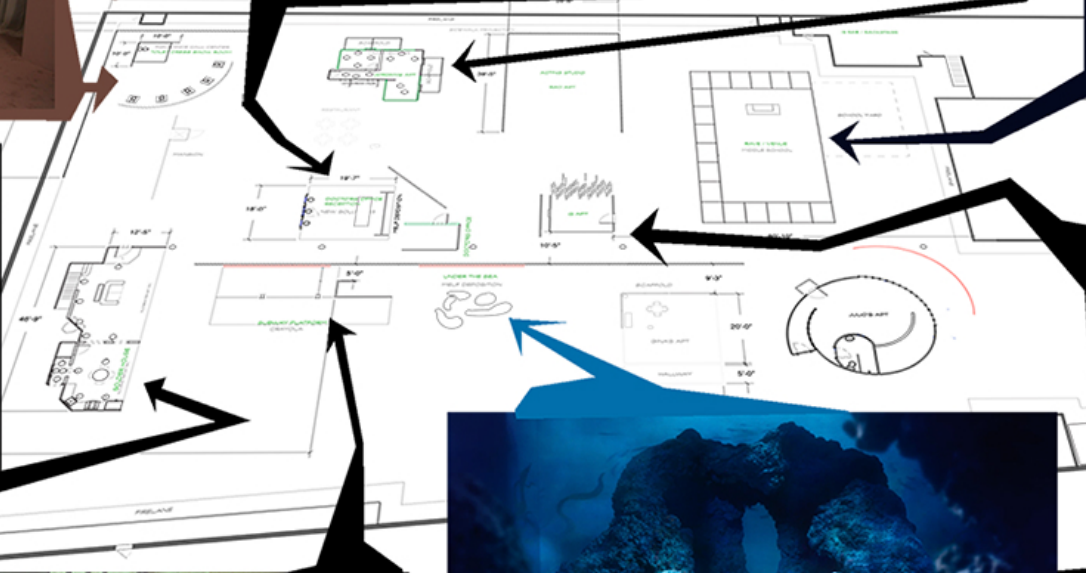

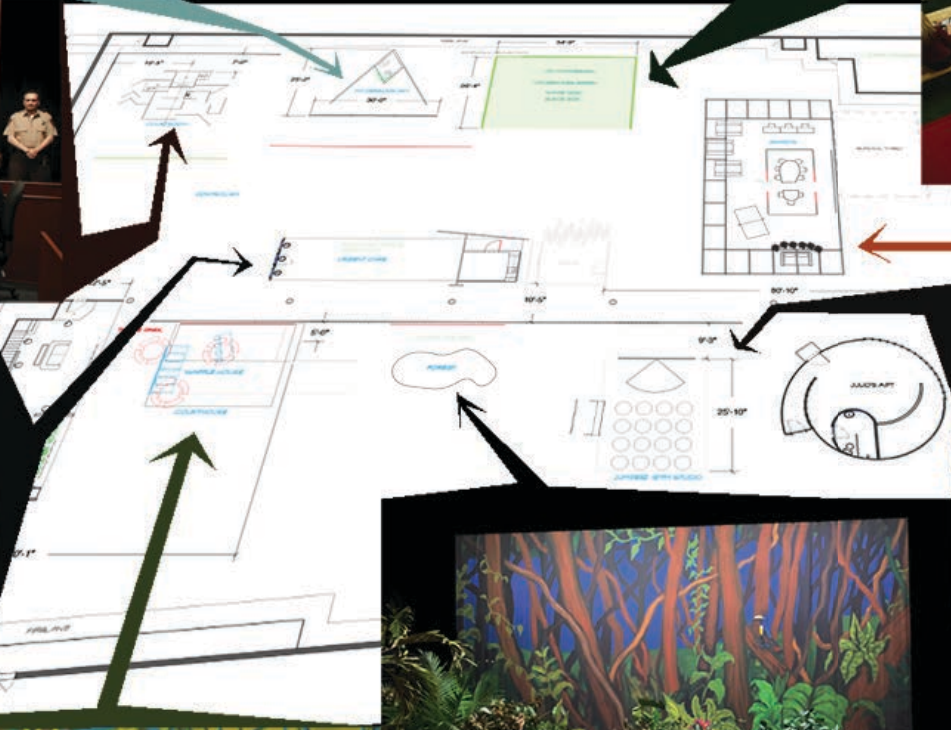
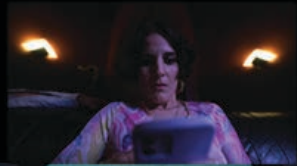

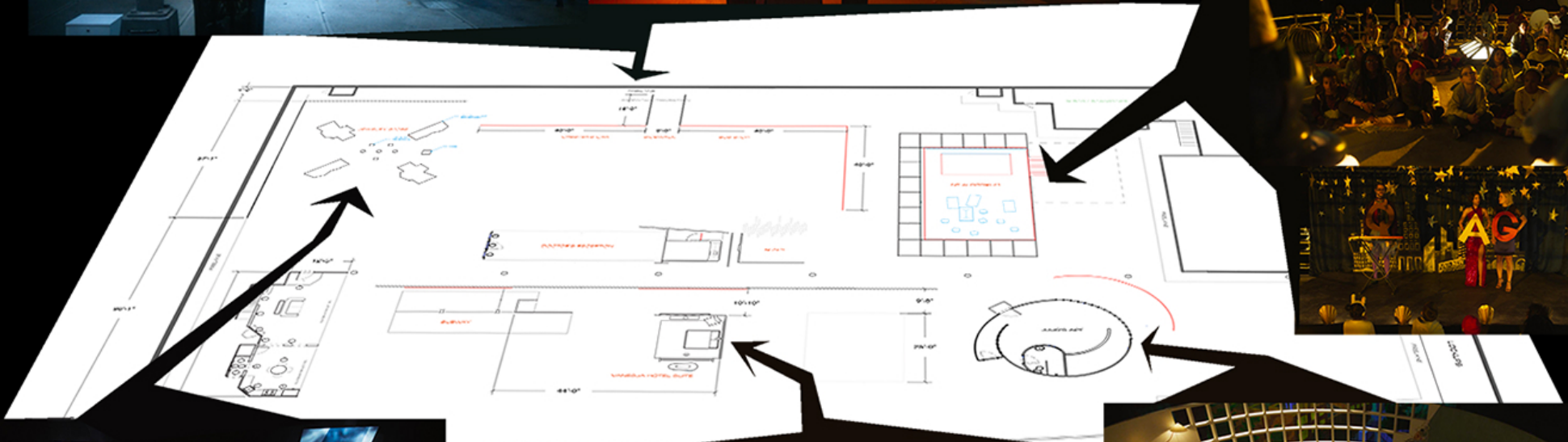



JULIO'S APT

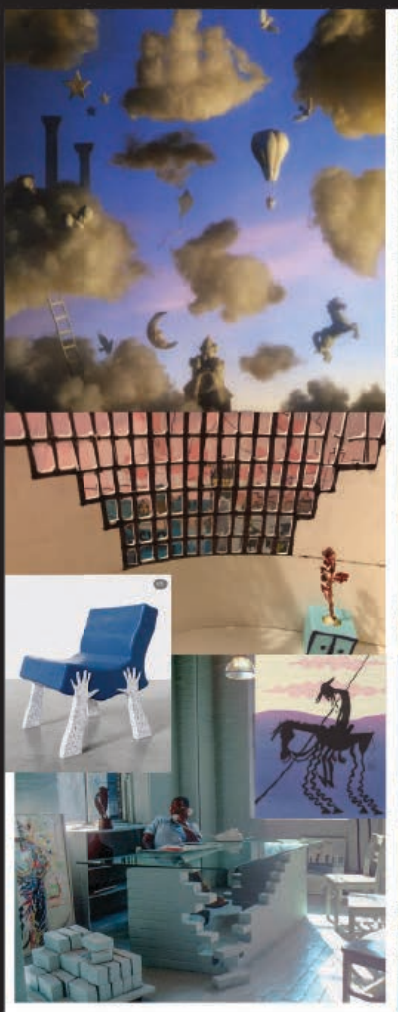
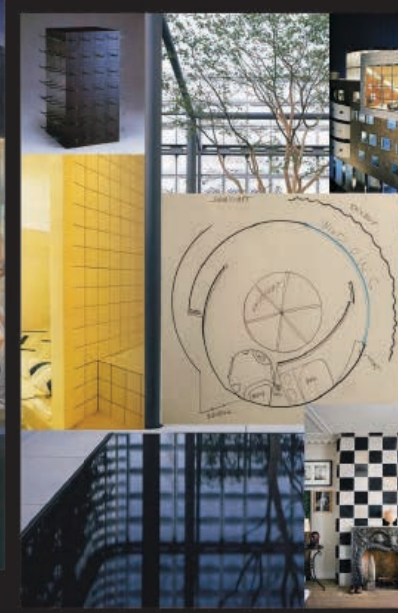

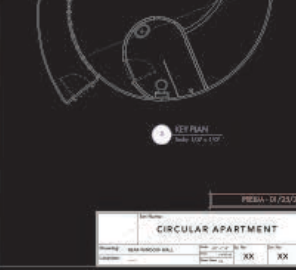
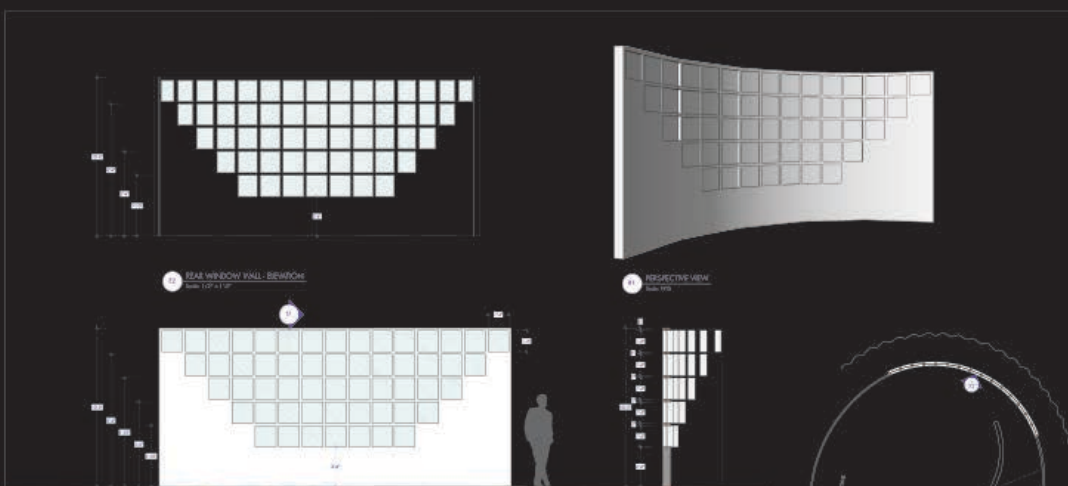

| PROJECT: 10/25/20 | |
|---------------------------|-----|
| CIRCULAR APARTMENT | 1/1 |
| DATE: 10/25/20 | 1/1 |
| SCALE: 1/2" = 1'-0" | 1/1 |
| 1/1 | 1/1 |

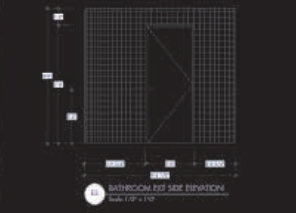
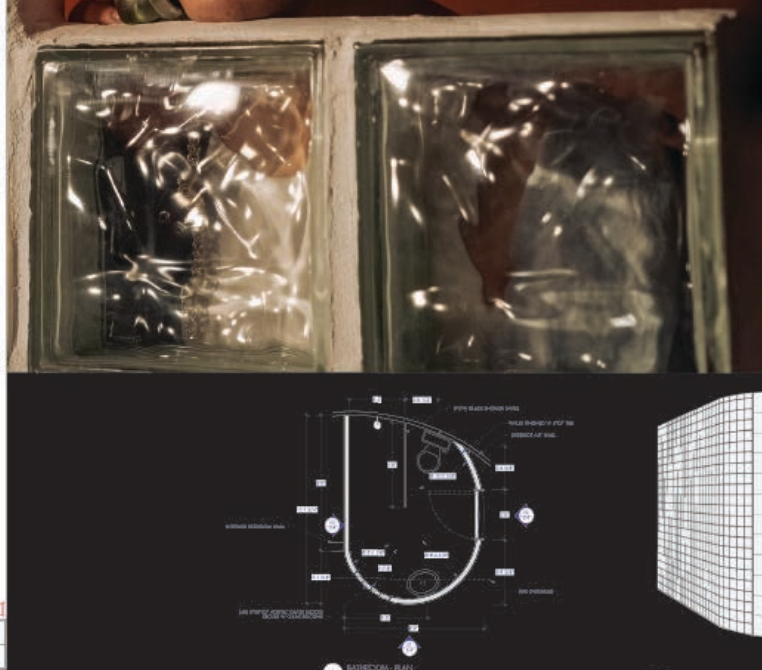
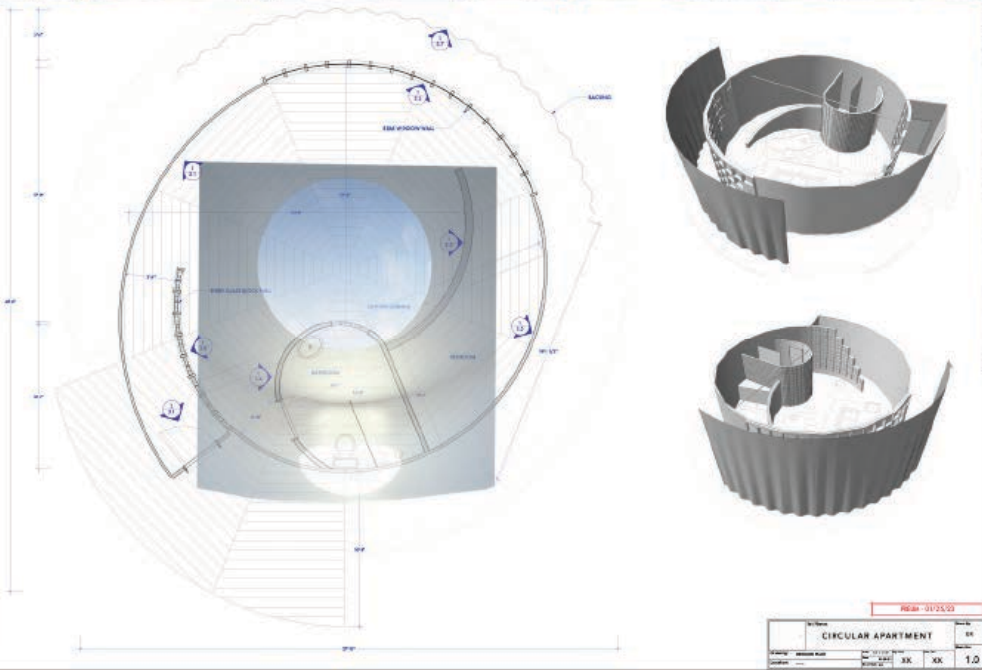

| PROJECT: 10/25/20 | |
|---------------------------|-----|
| CIRCULAR APARTMENT | 1/1 |
| DATE: 10/25/20 | 1/1 |
| SCALE: 1/2" = 1'-0" | 1/1 |
| 1/1 | 1/1 |



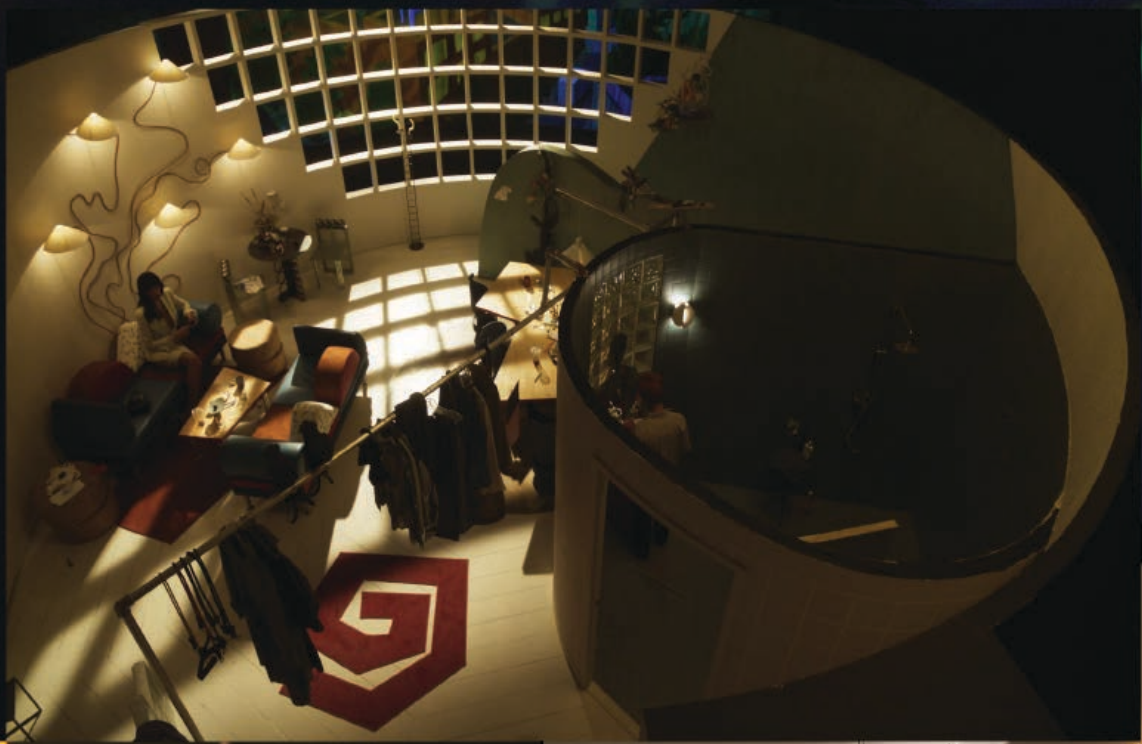



MELF



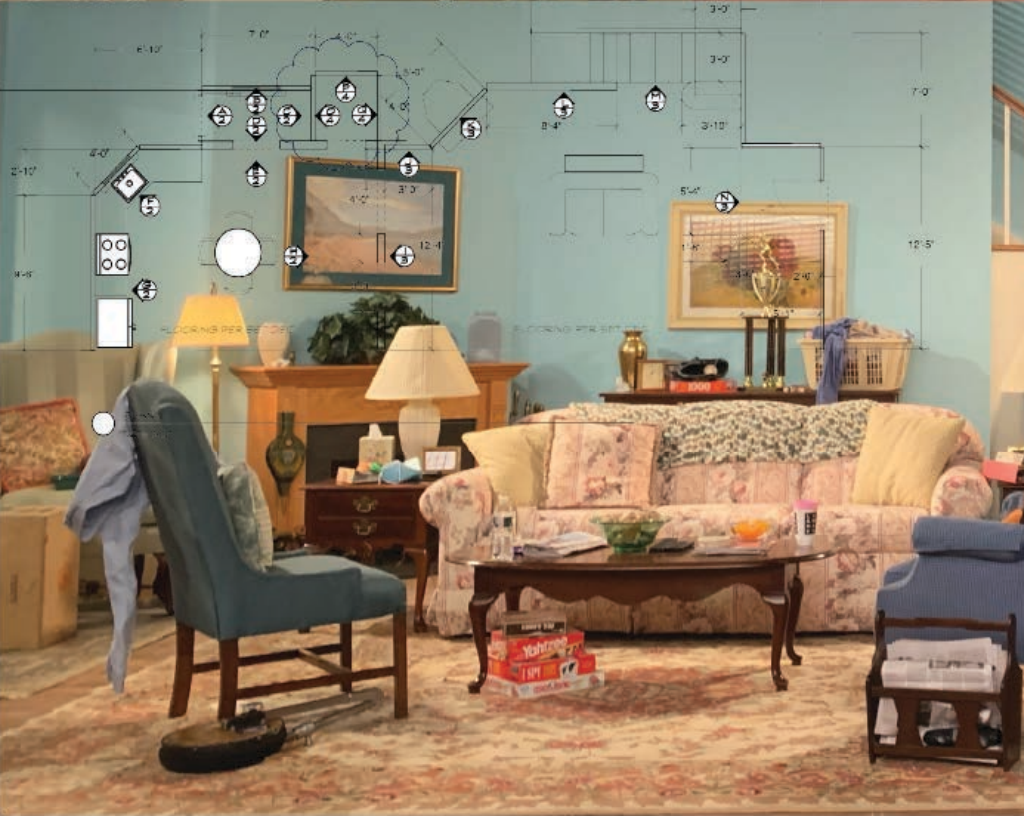



THE SKELETON STRUCTURE WAS TURNED INTO
4 DIFFERENT SETS, ONE FOR EACH PHASE



1

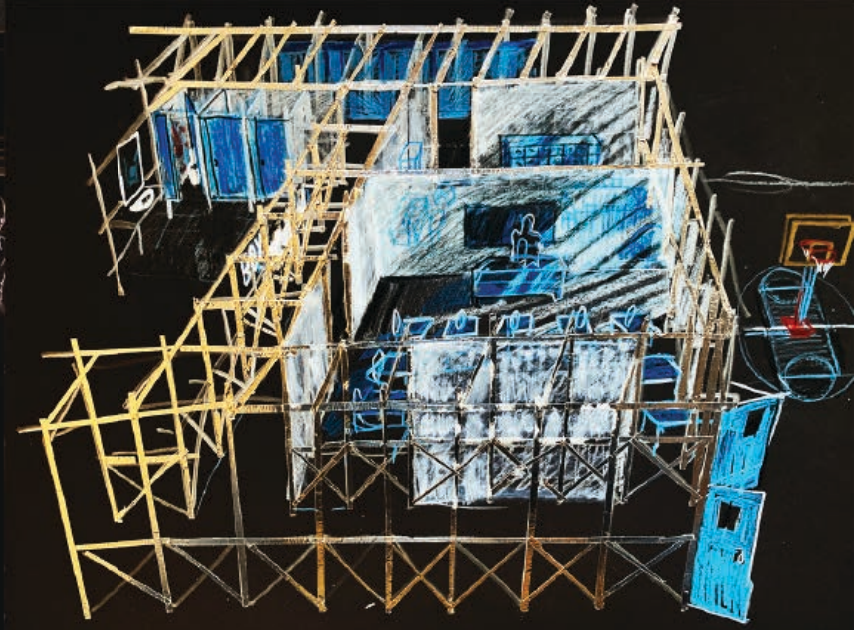

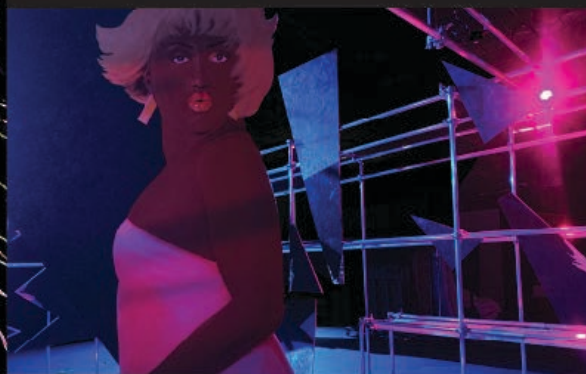
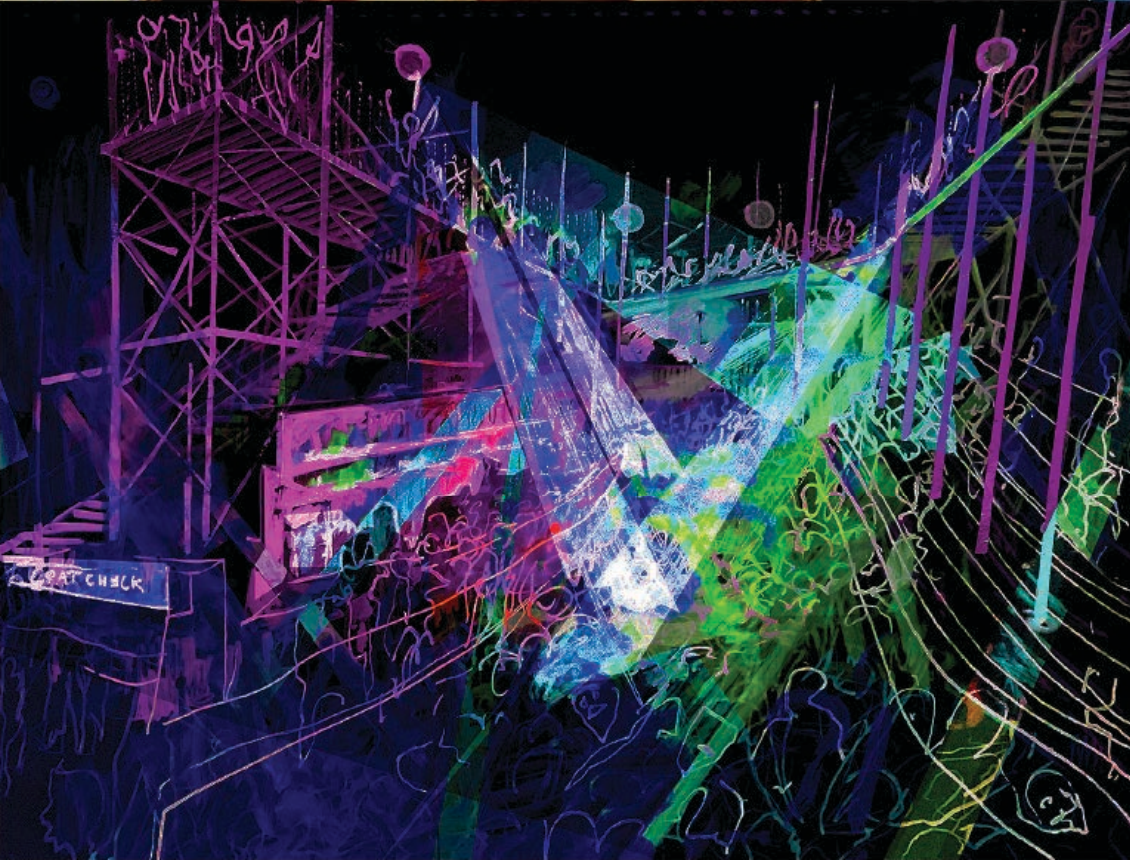

2

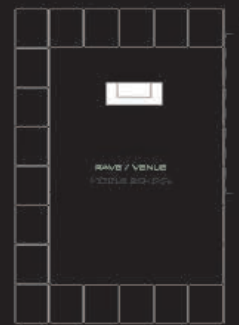

RAVE / VENUE
© 2018 RAVE / VENUE



3

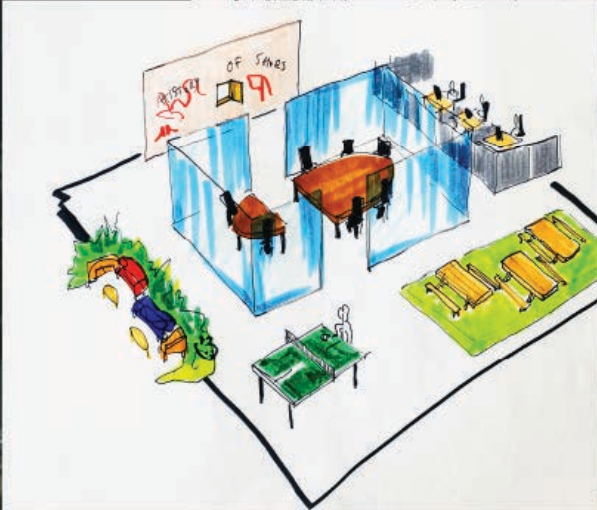
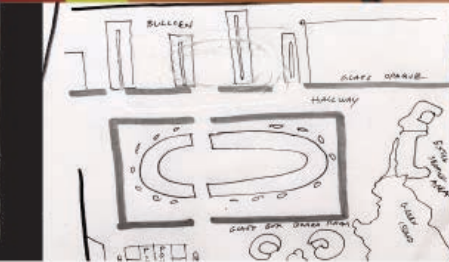



4

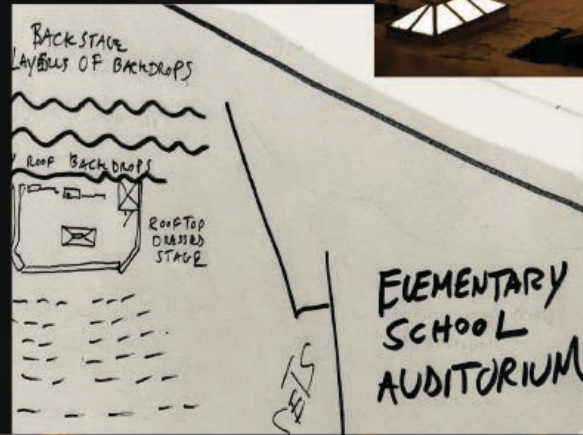



THE STREET









